

SIMPLEX[®]

Positioning & Lifting Equipment Specialists

ips

POW'R-RISER[®]

AVAILABLE NOW!

Heavy-Duty, Off-Road Equipment and Railcar Lifting

- ✓ 24", 26" and 37" Minimum Heights
- ✓ 60, 100, 150 and 200-ton capacities to handle the toughest jobs
- ✓ 3-position handle for easy tilt-back and rolling
- ✓ Easy-to-change external filter minimizes down time
- ✓ 4" of ground clearance for rough terrain
- ✓ Standard 12' pendant cord for air-driven units and 20' pendant cord for electric-driven keeps the operator away from the load during operation
- ✓ Dual hydraulic locking systems prevent creep down
- ✓ Equipped with a pilot-operated check valve which locks the load in place
- ✓ Optional Extension System and Mechanical Locking U-Rings are available



For over a century, Simplex has been known for its industrial positioning equipment capabilities. The POW'R-RISER is the only choice for the toughest, large-capacity lifting applications.

NOTHING ELSE COMES CLOSE:

- Rugged, fully enclosed frame; no exposed fittings or hoses
- Runs on air, 115VAC/15 amp, 230VAC/10, or 230 VAC, 3-phase service
- Secondary back-up filtration system for reliability.
- Light weight for greater mobility and positioning.
- Automatically controlled, "chatter free" load lowering for maximum safety in descent
- All Pow'r-Riser models comply with ASME/ANSI B30.1 Specifications

POW 'R-RISER[®]

Heavy Duty, Off Road Equipment & Railcar Lifting

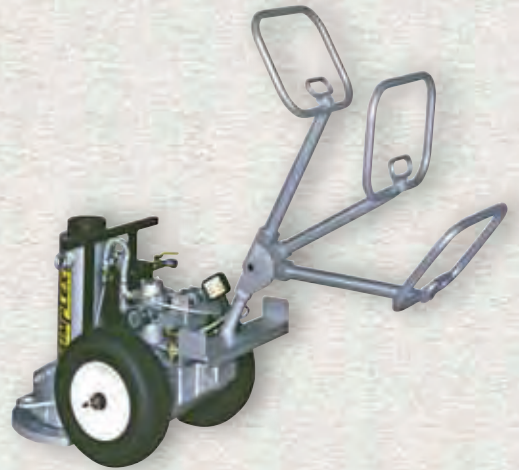

JAS10026 SHOWN WITH 3-POSITION HANDLE
SEE TABLE FOR ADDITIONAL MODELS

IDEAL FOR LIFTING APPLICATIONS SUCH AS...



Rail Yard



Off Road / Mining

Product Dimensions				
Model	"A" (in)	"B" (in)	"C" (in)	"D" (in)
JE6024	24	7	14	5
JE6037	37	7	14	
JE10026	26	7	18	5
JE10037	37	7	18	
JE15026	26	8	18	6
JE15037	37	8	18	
JAS20026	26	9.5	20	6.5
JAS20037	37			

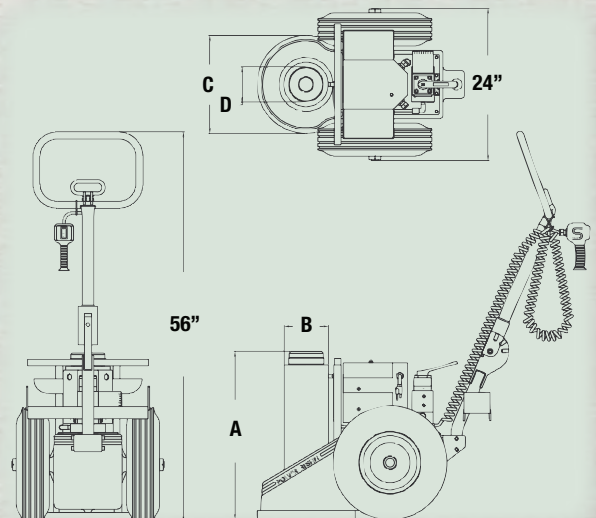



Simplex Pow'r-Risers™ are used to pick up the largest off road and railcars in the world. "We use the Simplex jack due to its easy transport and the many optional extensions and lock rings that ensures the level of safety required in mining operations."

JAS20037 SHOWN WITH OPTIONAL SUP-R-STACK™ EXTENSION SYSTEM. SEE TABLE FOR ADDITIONAL MODELS

SIMPLEX POW'R-RISERS ARE THE IDEAL CHOICE FOR RAILCAR AND OFF-ROAD EQUIPMENT JACKING

Product Ordering & Specifications

Model	Capacity (tons)	Min. Height (in)	Stroke (in)	Max. Additional Stack Height Using Optional Extension System	Motor	Control Valve	Power Source	Noise Level (Db)	Weight (lbs)			
JA6024	60	24	14	32*	Air	Manual	Air Motor 50 CFM 80 PSI	89	390			
JA6037		37	27	11*					600			
JE6024		24	14	32*	Electric		115 VAC 50/60 Hz 20 amps	80	390			
JE6037		37	27	11*					600			
JA10026	100	26	16	21**	Air	Manual	Air Motor 50 CFM 80 PSI	89	510			
JA10037		37	27	11**					600			
JAS10026		26	16	21**		Remote 12' Pendant			510			
JAS10037		37	27	11**						600		
JE10026		26	16	21**	Electric	Manual	115 VAC 50/60 Hz 20 amps	80	510			
JE10037		37	27	11**					600			
JEB10026		26	16	21**			230 VAC 3 Phase	530				
JEB10037		37	27	11**					620			
JAS15026		150	26	15.5			21**	Air	Remote 12' Pendant	Air Motor 50 CFM 80 PSI	89	570
JAS15037			37	26.5			11**					708
JE15026	26		15.5	21**	Electric	Manual	115VAC	80	570			
JE15037	37		26.5	11**					708			
JEB15026	26		15.5	21**			230 VAC 3 Phase		590			
JEB15037	37		26.5	11**						728		
JAS20026	200	26	15.3	21**	Air	Remote 12' Pendant	Air Motor 50 CFM 80 PSI	89	640			
JAS20037		37	24.3	11**					825			

Note: To order 230VAC single phase units, add an "A" to the end of the model number.

* Based on (1) 18" and (1) 11" extension and (1) 3" spacer.

**Based on (1) 18" extension and (1) 3" spacer.

WARNING: Any two extensions may be stacked for loads up to 60 tons per jack.

For loads from 60 tons to 150 tons only 1 extension and 1 spacer can be used.

The Simplex Pow'r-Riser, When Used With The Extension Set and Spacer Set, Can Handle All Rail Cars and Off-Road Equipment Without Blocking.

EXTENSIONS



Product Ordering & Specifications	
Model	Contents
JE5	5" Extender
JE7	7" Extender
JE9	9" Extender
JE11	11" Extender
JE14	14" Extender
JE18	18" Extender
ES6024	5", 7", 11", 18" Extenders

SPACERS

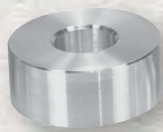

Product Ordering & Specifications	
Model	Contents
JS1	1" Spacer - Qty. 1
JS2	2" Spacer
JS3	3" Spacer
JS4	(2) 1", 2", 3" Spacers

(Use one extension and one spacer only for loads over 60 tons)
Use tallest extender on the bottom.
Fine tune your extension stack height by adding 1", 2" or 3" spacer.

SWIVEL LOAD CAP



Product Ordering & Specifications	
Model	Description
JTS60	60 & 100-Ton
JTS150	150 Ton
JTS200	200 Ton

LOCKING U-RING SETS

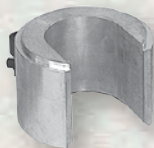

Product Ordering & Specifications		
Model	Models Used On	Contents
JU110	60 & 100 Ton	10" Extender
JU14	60 & 100 Ton	4.25" Extender
JU13	60 & 100 Ton	3" Extender
JU11	60 & 100 Ton	1" Extender
JU1510	150 Ton	10" Extender
JU155	150 Ton	5.5" Extender
JU153	150 Ton	3" Extender
JU151	150 Ton	1" Extender
JUS126	60 Ton 24"/100 Ton 26"	(2) JU11 - 1", (1) JU13 - 3", (2) JU14 - 4.25"
JUS137	60 Ton 37"/100 Ton 37"	(2) JU11 - 1", (1) JU13 - 3", (2) JU14 - 4 1/4", (1) JU110 - 10"
JUS1526	150 Ton 26"	(2) JU151 - 1", (1) JU153 - 3", (2) JU155 - 5.5"
JUS1537	150 Ton 37"(2)	JU151 - 1", (1) JU153 - 3"(1) JU1510 - 10", (2) JU155 - 5.5"
JUS2026	200 Ton 26"	(2) JU201 - 1", (1) JU203 - 3", (2) JU205 - 5"
JUS2037	200 Ton 37"	(2) JU201 - 1", (1) JU203 - 3", (4) JU205 - 5"

• **Extensions** - Add extra height without utilizing piston stroke.

• **Spacers** - Fine-tune your extension height in small increments.

• **Locking U-Rings** - Provides mechanical load holding and added safety.

• **Swivel Load Caps** - Distributes the load on center for non-perpendicular lifting.

